

GPS Engine Board

(GE415P-X)

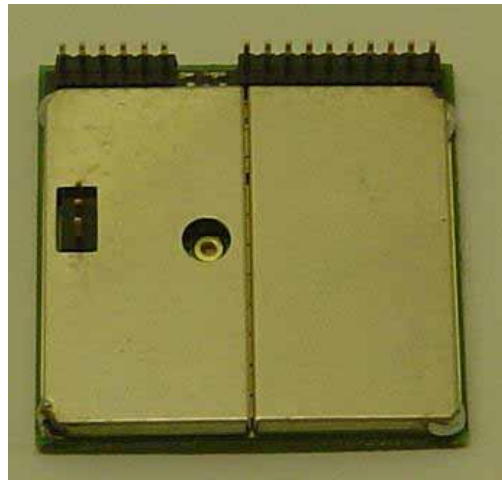

(GE415)



User's Manual

Ver 2.0

Contents

1. INTRODUCTION.....	2
1.1 OVERVIEW.....	2
1.2 MAIN FEATURES.....	2
2. TECHNICAL SPECIFICATIONS.....	3
2.1 ELECTRICAL CHARACTERISTICS.....	3
2.2 ENVIRONMENTAL CHARACTERISTICS.....	4
2.3 PHYSICAL CHARACTERISTICS.....	4
3. MECHANICAL DIMENSIONS.....	5
3.1 GE415.....	5
3.2 GE415P-1.....	6
GE415P-2.....	7
4. PIN ASSIGNMENT OF CONNECTOR.....	8
4.1 SERIAL INTERFACE.....	8
4.2 DEBUG INTERFACE.....	9
5. APPLICATIONS.....	10
6. OPERATION AND TEST.....	10
APPENDIX A: OTHER ELECTRICAL SPECIFICATIONS.....	11
APPENDIX B: REFERENCE DESIGN.....	12
APPENDIX C: SOFTWARE SPECIFICATION.....	13

1. Introduction

1.1. Overview

The GPS module GE415/GE415P (patch on top) is a high sensitivity ultra low power consumption cost efficient, compact size; plug & play GPS module board designed for a broad spectrum of OEM system applications. This product is based on the proven technology found in other our 16 channel GPS receivers and NEMERIX chipset solution. The GPS module receiver will track up to 16 satellites at a time while providing fast time-to-first-fix and 1Hz navigation updates. Its far reaching capability meets the sensitivity & accuracy requirements of car navigation as well as other location-based applications, such as AVL system. Handheld navigator, PDA, pocket PC, or any battery operated navigation system.

The GE415/GE415P design utilizes the latest surface mount technology and high level circuit integration to achieve superior performance while minimizing dimension and power consumption. This hardware capability combined with software intelligence makes the board easy to be integrated and used in all kinds of navigation applications or products. The module communicates with application system via RS232 (TTL level) with NMEA0183 protocol.

1.2. Main Feature

- Built-in high performance NEMERIX chipset.
- Average Cold Start in 60 seconds.
- Ultra Low power consumption.(GE415 27mA typ @ 3.3V)
- 16 channels “All-in-View” tracking.
- On chip 4Mb flash memory.
- TTL level serial port for GPS receiver command message Interface.
- Compact Board Size

GE415	1.043”x1.043”x0.11”(26.5x26.5x3.0mm)
GE415P-4	1.043”x1.043”x0.34”(26.5x26.5x8.7mm)
GE415P-2	1.043”x1.043”x0.26”(26.5x26.5x6.7mm)

For easy integration into hand-held device.

- Support Standard NMEA-0183 V3.0
- Multi-path Mitigation Hardware
- Optimum clock drift adjustment
- External antenna open/short detector
- Support dual antenna with built-in auto-detect RF switch (GE415P)

2. Technical Specifications

2.1. Electrical Characteristics

2.1.1 General

Frequency	L1, 1575.42 MHz
C/A code	1.023 MHz chip rate
Channels	16

2.1.2 Sensitivity

Tracking	-152dBm typ
Acquisition	-139dBm typ

2.1.3 Accuracy

Position	7 meters CEP (90%) horizontal, SA off.
Velocity	0.1 meters/second
Time	1 microsecond synchronized to GPS time

2.1.4 Datum

Default	WGS-84
Other	Support different datum by request

2.1.5 Acquisition Rate (Open sky, stationary requirements)

Hot start	12 sec, average
Warm start	38 sec, average
Cold start	60 sec, average

2.1.6 Dynamic Conditions

Altitude	10,000 meters max
Horizontal Velocity	300 kilometers/hour max
Vertical Velocity	36 kilometers/hour max
Acceleration	2g, max
Jerk	4 meters/second ³ , max

2.1.7 Power

Main power input	3.3 ±5% VDC input.
Supply Current	GE415 27 mA @ 3.3V(Continuous mode) GE415P 33 mA @ 3.3V (Continuous mode) including LNA

2.1.8 Serial Port

Electrical interface	one full duplex serial communication, TTL interface
Protocol message	NMEA-0183, version 3.0 optional.
Default NMEA	GGA, GSA, GSV, RMC and VTC. 9600 baud rate, 8 bits data, 1 start, 1 stop, no parity. (GSA & GSV is 3sec output 1msg, option baud rate: 4800,19200, 38400)

2.1.9 Time-1PPS Pulse (optional)

Level	TTL
Pulse duration	100ms
Time reference	at the pulse positive edge
Measurements	Aligned to GPS second, +-1 microsecond

2.1.10 Recommended External Antenna Specification

Gain	20dB (including cable loss)
Noise figure	1.5dB
Current	3 ~ 30mA
Operate Voltage	2.5 ~ 2.8V

2.2. Environmental Characteristics

Operating temperature range	-40 deg. C to +80 deg. C
Storage temperature range	-55 deg. C to +100 deg. C

2.3. Physical Characteristics

Dimension: GE415	1.043"x1.043"x0.11" (26.5x26.5x3.0mm)
GE415P-1	1.043"x1.043"x0.34" (26.5x26.5x8.7mm) (With TH: 4mm patch antenna)
GE415P-2	1.043"x1.043"x0.26" (26.5x26.5x6.7mm) (With TH: 2mm patch antenna)
Weight: GE415	3.8g
GE415P-1	15g
GE415P-2	10.4g

Antenna connector: 1.27 mm pitch 3 pin board to board

Interface connector: 1.27 mm pitch 10 pin / 6 pin board to board

Remarks: Difference between GE415 & GE415P.

GE415: one rf input with antenna detector.

(Use Active antenna only)

GE415P: two rf input with auto switch.

(One patch antenna, one external antenna)

Mechanical Dimensions

3.1. GE415

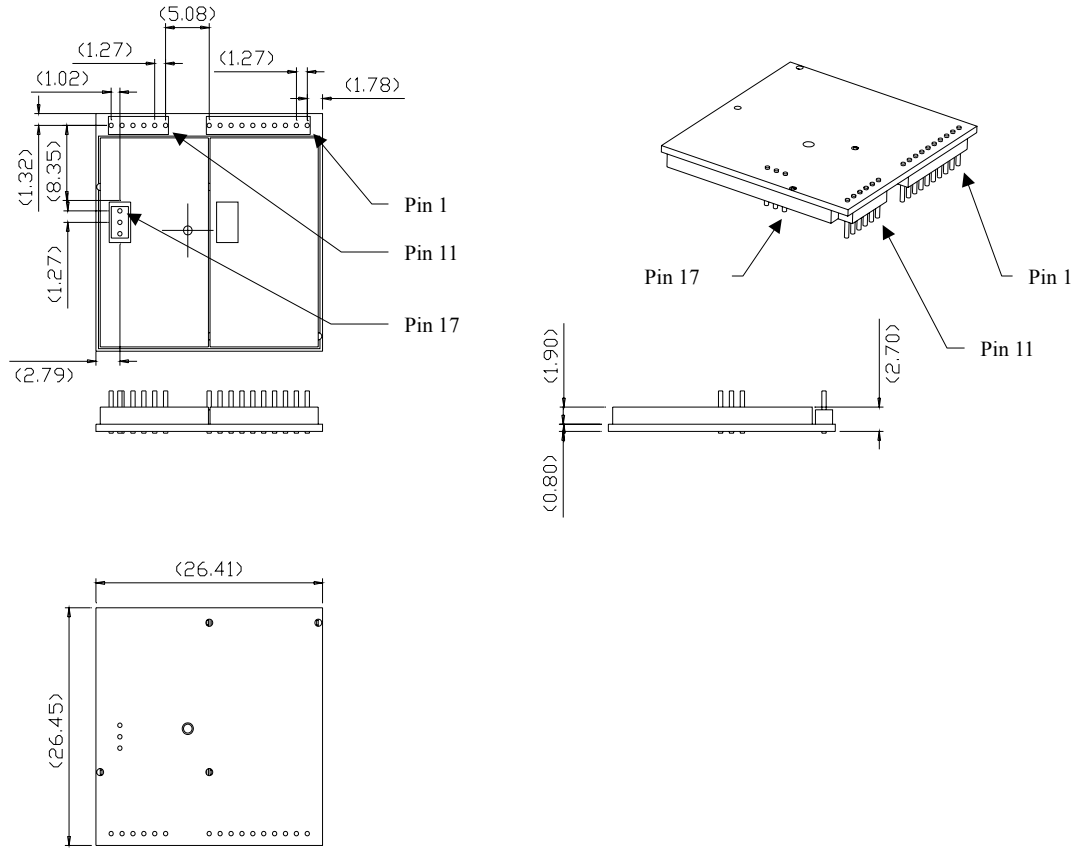

Pin	Name	Pin	Name
1	GPIO [4]	11	DSUMUX
2	NC (MODE)	12	DSUEN
3	NMEA TX	13	DSUBRE
4	NMEA RX	14	DSUTX
5	NC(WAKE UP)	15	DSURX
6	Reset	16	DSUACT
7	VBAT	17	RF GND
8	GND	18	RF IN
9	VDD	19	RF GND
10	GPIO [0]		

*Pin Assignment please refers to the Table 3-1.

3.2. GE415P-1

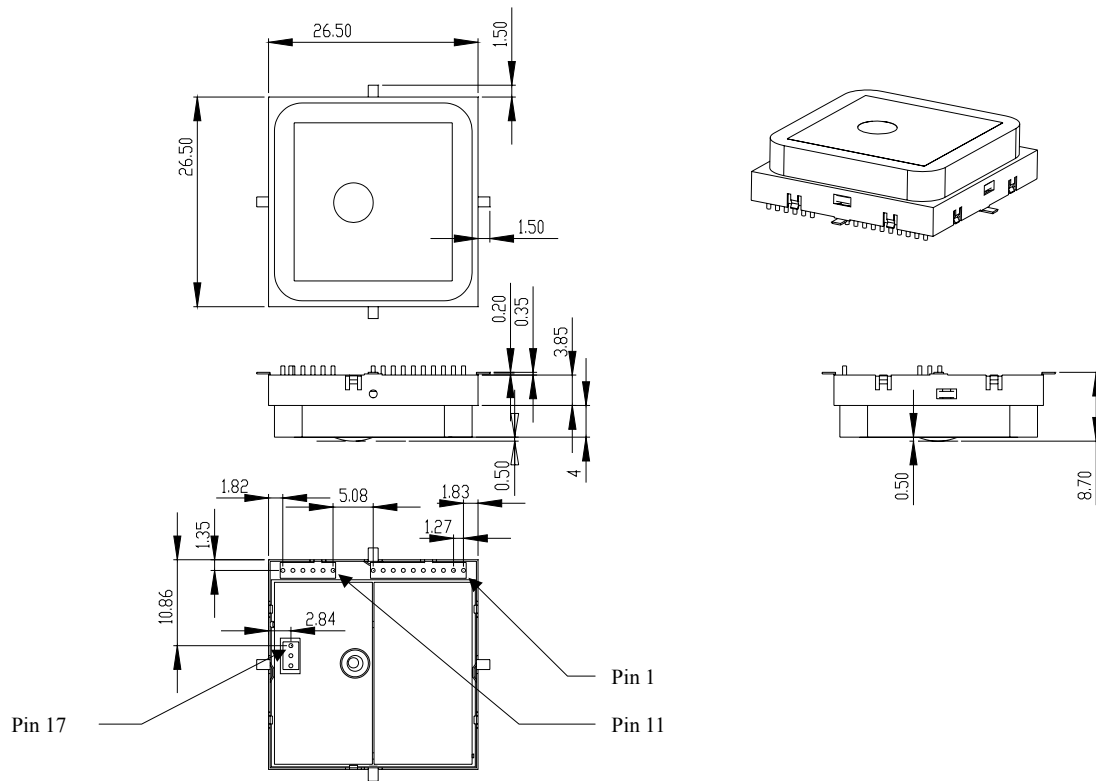

Pin	Name	Pin	Name
1	GPIO [4]	11	DSUMUX
2	NC (MODE)	12	DSUEN
3	NMEA TX	13	DSUBRE
4	NMEA RX	14	DSUTX
5	NC(WAKE UP)	15	DSURX
6	Reset	16	DSUACT
7	VBAT	17	RF GND
8	GND	18	RF IN
9	VDD	19	RF GND
10	GPIO [0]		

*Pin Assignment please refers to the Table 3-1.

GE415P-2

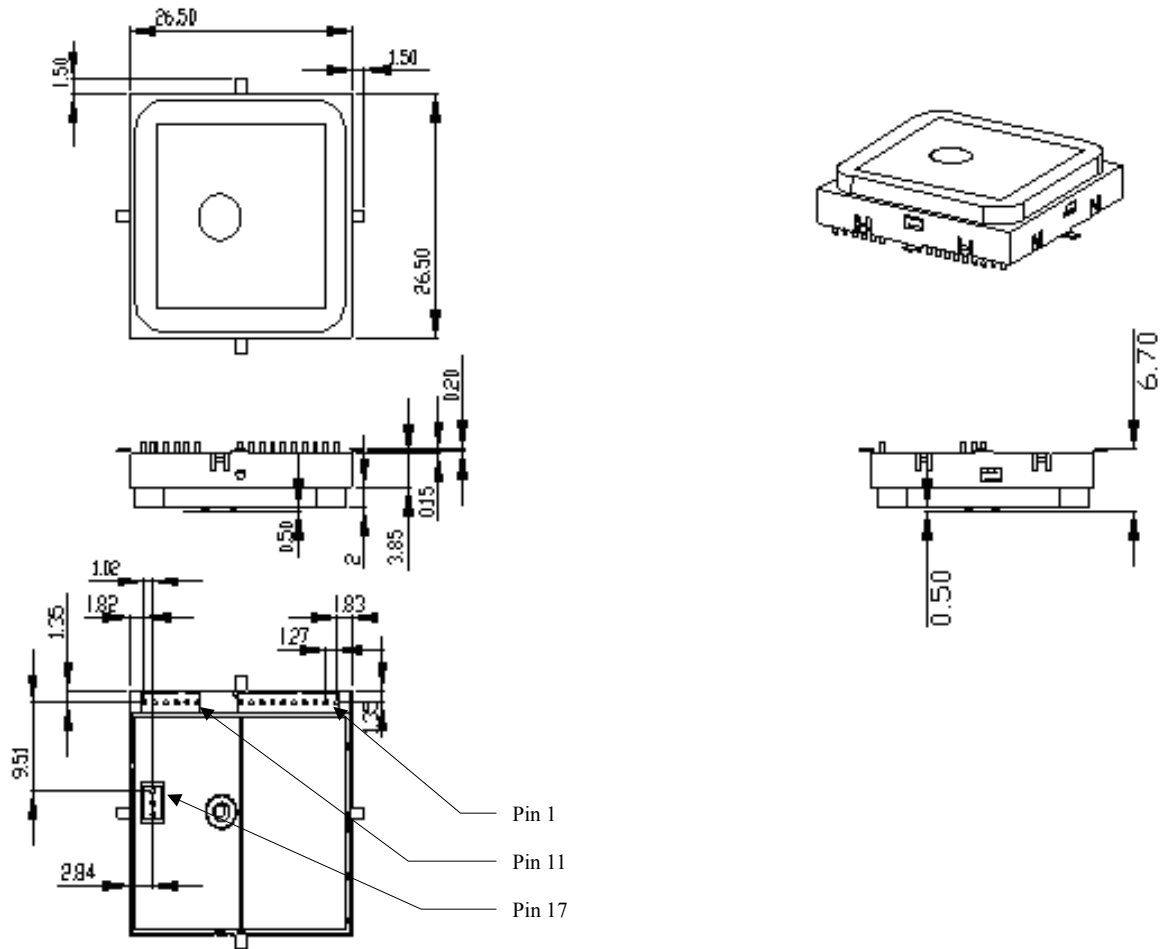

Pin	Name	Pin	Name
1	GPIO [4]	11	DSUMUX
2	NC (MODE)	12	DSUEN
3	NMEA TX	13	DSUBRE
4	NMEA RX	14	DSUTX
5	NC(WAKE UP)	15	DSURX
6	Reset	16	DSUACT
7	VBAT	17	RF GND
8	GND	18	RF IN
9	VDD	19	RF GND
10	GPIO [0]		

*Pin Assignment please refers to the Table 3-1.

3. Pin Assignment of Connector

3.1. Serial Interface

Communication to the GE415 is provided via a serial interface. A 10-pin 1.27mm whole connector is used. The pin out is shown in Table 4-1.

Pin 6 (Reset) is the active-low reset input. The GE415 always requires a reset at power-up, or it will not start properly. An optional onboard reset circuit can be provided. A reset forces the GE415 processor to reboot, but will not influence other parameters such as hot or cold start. Pin 1 (GPIO [4]) and pin 10 (GPIO [0]) are spare pins that can be used e.g. to control power modes, to indicate GE415 status, or to force a cold start. They can be left unconnected if desired.

I/O voltage level is set to 2.7V.

Table 3-1 Pin list of the Serial Interface

Pin	Name	Type	Description
1	GPIO [4]	I/O	GPS Status
2	NC (MODE)	NU	Reserved, keep float
3	NMEA TX	I/O	NMEA Serial Data Output
4	NMEA RX	I/O	NMEA Serial Data Input
5	NC (WAKEUP)	NU	Reserved, keep float
6	Reset	I	Low Active, keep float if not use *1
7	VBAT	I	Backup Battery Input (1.2~2V)
8	GND	PWR	Ground
9	VDD	PWR	+3.0~3.6V DC Power Input
10	GPIO [0]	I/O	SW dependent functions

*1: Max voltage is DC 2V.

3.2. Debug Interface

A dedicated pin out (in form of test points) is provided on the board to give the possibility to connect the GE415 debug unit. The debug port is intended to be used only during the development stage and to download the firmware at factor setup. It is not meant to be used by the customers unless they want to develop or modify the SW of the GE415 module.

The debug port includes the signals required by the debug system unit (DSU). A companion DSU interface board has been already developed.

Table 3-2 Pin list of the Debug Interface

Pin	Name	Type	Description
1	DSUMUX	I	Serial / DSU select
2	DSUEN	I	DSU enable
3	DSUBRE	I	DSU break enable
4	DSUTX	O	DSU transmitter
5	DSURX	I	DSU receiver
6	DSUACT	O	DSU active

4. Applications

GE415 module board receiver is a high performance, ultra low power consumption, plug & play product. These applications are as follow.

- Car Navigation
- Wrist Watch
- Solar Operated Device
- Marine Navigation
- Fleet Management
- AVL and Location-Based Services
- Radar detector with GPS function
- Hand-Held Device for Personal Positioning and Navigation
- Ideal for PAD, Pocket PC and Other Computing Devices at GPS Application

5. Operation and Test

The customers can change the data protocol and communication data baud rate for your application using this software. The software and manual are available for download from website.

Appendix A: Other Electrical Specifications

Table A-1 Absolute Maximum Ratings

Parameter	Symbol	Min	Max	Units
Power Supply Voltage	VDD	-0.3	3.6	V
Input Pin Voltage	VIN	-0.3	3.3	V
Output Pin Voltage	VOUT	-0.3	3	V
Reset Pin Voltage	V _{reset}	-0.3	2.0	V
Storage Temperature	TSTG	-40	100	°C
Back-up Voltage	BAT		2.2	V

Table A-2 Operating Conditions

Parameter	Symbol	Min	Typ	Max	Units
Power Supply Voltage	VDD	3	3.3	3.6	V
Input Pin Voltage	VIN	2.7	3	3.3	V
Operating Temperature	TOPR	-40		85	°C
Operating Current GE415	ICC		27		mA
Operating Current GE415P	ICC		30		mA

Table A-3 Backup Battery Conditions

Parameter	Symbol	Min	Typ	Max	Units
RTC(Battery) Power	BAT	1.2	1.8	2	V
Supply Current			10		μA

Table A-4 DC Characteristics

Parameter	Symbol	Min	Max	Units
Input High Level	V _{ih}	2.5	3.5	V
Input Low Level	V _{il}	0	0.8	V
Output High Level	V _{oh}	2.4	3.4	V
Output Low Level	V _{ol}	0	0.4	V
Input Leakage Current	I _i	2	2	μA

Appendix B: Reference Design

Backup Battery reference design :
(rechargeable Lithium battery)

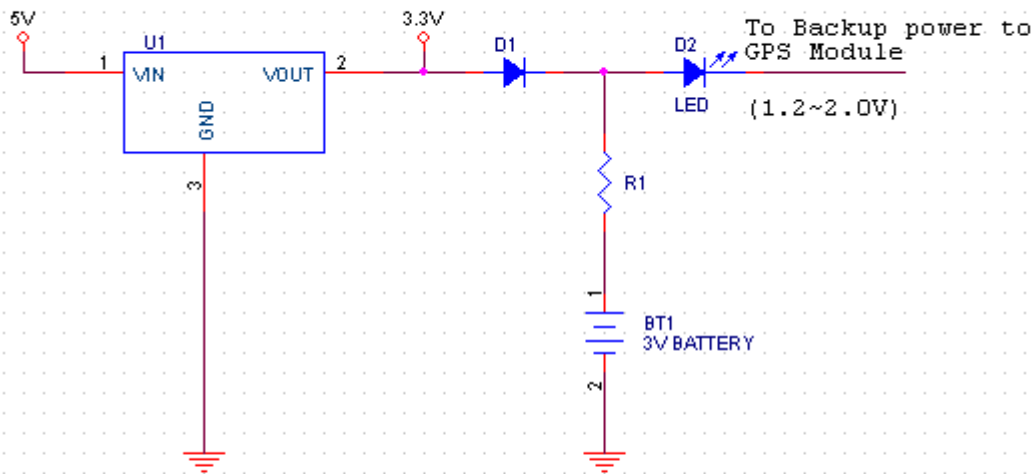

U1 constant voltage element
D1 select a shotkey diode of small inverse current
R1 selected depend on charge voltage of battery

for example :

U1 : RT9167-33CB (RICHTEK)
D1 : BAT54 (FAIRCHILD)
R1 : 100 Ohm
D2 : LED
Battery : ML414S (Panasonic)

Backup Battery reference design :
(rechargeable Nimh battery)

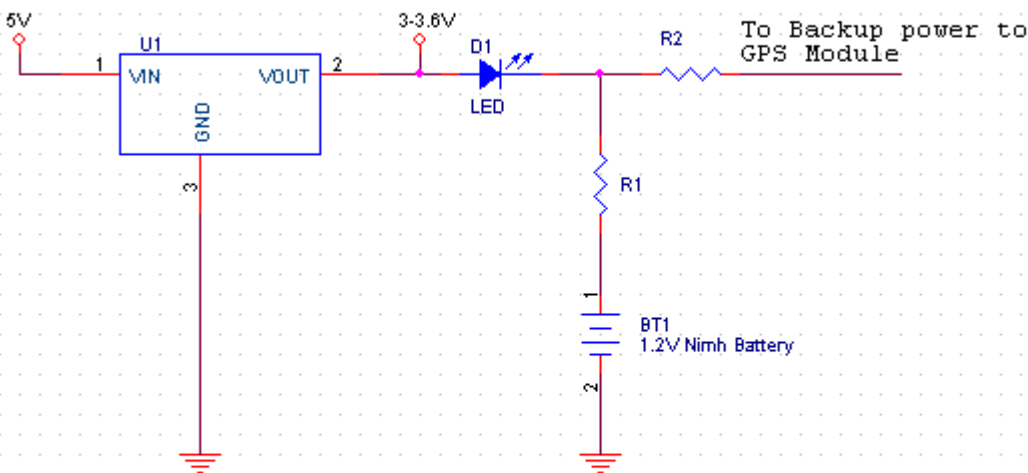

U1 constant voltage element
D1 select a led to drop voltage
R1& R2 selected depend on charge voltage of battery
Wonde-X Charging rate (0.05C-0.1C)

for example :
U1 : RT9167-33CB (RICHTEK)
D1 : LED
Battery : 1.2V Nimh Battery

Appendix C: Software Specification

GE415 NMEA Protocol

The GE415 software is capable of supporting the following NMEA message formats

NMEA Message Prefix	Format	Direction
SGPGGA(1)*	GPS fix data.	Out
SGPGLL	Geographic position Latitude / Longitude.	Out
SGPGSA(3)*	GNSS DOP and actives satellites	Out
SGPGSV(3)*	Satellites in view.	Out
SGPRMC(1)*	Recommended minimum specific GNSS data.	Out
SGPVTG(1)*	Velocity and track over ground.	Out
SGPZDA	Date and time.	Out

*: (1): 1sec output 1msg , (3): 3sec output 1msg , 9600 baud rate (Standard output)

GE415 NMEA Extensions

The GE415 software is capable of supporting the following NMEA extensions:

NMEA Message Prefix	Format	Direction
\$PNMRX100	Set serial port parameters.	In
\$PNMRX101	Navigation initialization	In
\$PNMRX103	NMEA message rate control	In
\$PNMRX104	LLA navigation initialization	In
\$PNMRX106	Set Datum.	In
\$PNMRX107	Nemerix messages rate control	In
\$PNMRX108	NMEA message sequence control	In
\$PNMRX110	Fix Settings	In
\$PNMRX111	Software Reset	In
\$PNMRX112	Operating Mode Control	In
\$PNMRX113	Fix and Extraction control	In
\$PNMRX300	Almanac data transfer	In / Out
\$PNMRX301	Ephemeris data transfer.	Out
\$PNMRX302	Ionospheric correction	Out
\$PNMRX303	UTC Time	Out
\$PNMRX304	GPS Constellation Health Status	Out
\$PNMRX600	SW Version report	Out
\$PNMRX601	ISP mode	In
\$PNMRX602	Flash content version report	Out
\$PNMRX603	Settings Report	Out

General NMEA Format

The general NMEA format consists of an ASCII string commencing with a '\$' character and terminating with a <CR><LF> sequence. NMEA standard messages commence with 'GP' then a 3-letter message identifier. Nemerix specific messages commence with \$PNMRX followed by a 3 digit number. The message header is followed by a comma delimited list of fields optionally terminated with a checksum consisting of an asterix '*' and a 2 digit hex value representing the checksum. There is no comma preceding the checksum field. When present, the checksum is calculated as a bitwise exclusive of the characters between the '\$' and '*'. As an ASCII representation, the number of digits in each number will vary depending on the number and precision, hence the record length will vary. Certain fields may be omitted if they are not used, in which case the field position is reserved using commas to ensure correct interpretation of subsequent fields.

The tables below indicate the maximum and minimum widths of the fields to allow for buffer size allocation.

\$GPGGA

This message transfers global positioning system fix data. The \$GPGGA message structure is shown below:

Field	Format	Min chars	Max chars	Notes
Message ID	\$GPGGA	6	6	GGA protocol header.
UTC Time	hhmmss.sss	2,2,2.3	2,2,2.3	Fix time to 1ms accuracy.
Latitude	float	3,2.4	3,2.4	Degrees * 100 + minutes.
N/S Indicator	char	1	1	N=north or S=south
Longitude	float	3,2.4	3,2.4	Degree * 100 + minutes.
E/W indicator	Char	1	1	E=east or W=west
Position Fix Indicator	Int	1	1	0: Fix not available or invalid. 1: GPS SPS mode. Fix available.
Satellites Used	Int	2	2	Number of satellites used to calculate fix.
HDOP	Float	1.1	3.1	Horizontal Dilution of Precision.
MSL Altitude	Float	1.1	5.1	Altitude above mean seal level
Units	Char	1	1	M Stands for "meters".
Geoid Separation	Int	(0) 1	4	Separation from Geoids can be blank.
Units	Char	1	1	M Stands for "meters".
Age of Differential	int	(0) 1	5	Age in seconds Blank (Null) fields when DGPS is not used.

Corrections				
Diff Reference Corrections	int	4	4	0000.
Checksum	*xx	(0) 3	3	2 digits.
Message terminator	<CR> <LF>	2	2	ASCII 13, ASCII 10.

\$GPGLL

This message transfers Geographic position, Latitude, Longitude, and time. The \$GPGLL message structure is shown below:

Field	Format	Min chars	Max chars	Notes
Message ID	\$GPGLL	6	6	GLL protocol header.
Latitude	Float	1,2.1	3,2.4	Degree * 100 + minutes.
N/S Indicator	Char	1	1	N=north or S=south.
Longitude	Float	1,2.1	3,2.4	Degree * 100 + minutes.
E/W indicator	Character	1	1	E=east or W=west.
UTC Time	hhmmss.sss	1,2,2.1	2,2,2.3	Fix time to 1ms accuracy.
Status	Char	1	1	A Data Valid. V Data invalid.
Mode Indicator	Char	1	1	A Autonomous
Checksum	*xx	(0) 3	3	2 digits.
Message terminator	<CR><LF>	2	2	ASCII 13, ASCII 10.

\$GPGSA

This message transfers DOP and active satellites information. The \$GPGSA message structure is shown below:

Field	Format	Min chars	Max chars	Notes
Message ID	\$GPGSA	6	6	GSA protocol header.
Mode	Char	1	1	M Manual, forced to operate in selected mode. An Automatic switching between modes.
Mode	Int	1	1	1 Fix not available. 2 2D position fix. 3 3D position fix.
Satellites Used	Int	2	2	SV on channel 1.
Satellites Used	Int	2	2	SV on channel 2.
...
Satellites Used	Int	2	2	SV on channel 12.
PDOP	Float	1.1	3.1	
HDOP	Float	1.1	3.1	
VDOP	Float	1.1	3.1	
Checksum	*xx	0	3	2 digits
Message terminator	<CR> <LF>	2	2	ASCII 13, ASCII 10

\$GPGSV

This message transfers information about satellites in view. The \$GPGSV message structure is shown below. Each record contains the information for up to 4 channels, allowing up to 12 satellites in view. In the final record of the sequence the unused channel fields are left blank with commas to indicate that a field has been omitted.

Field	Format	Min chars	Max chars	Notes
Message ID	\$GPGSV	6	6	GSA protocol header.
Number of messages	Int	1	1	Number of messages in the message sequence from 1 to 3.
Message number	Int	1	1	Sequence number of this message in current sequence, form 1 to 3.
Satellites in view	Int	1	2	Number of satellites currently in view.
Satellite Id	Int	2	2	Satellite vehicle 1.
Elevation	Int	1	3	Elevation of satellite in degrees.
Azimuth	Int	1	3	Azimuth of satellite in degrees.
SNR	Int	(0) 1	2	Signal to noise ration in dBHz, null if the sv is not in tracking.
Satellite Id	Int	2	2	Satellite vehicle 2.
Elevation	Int	1	3	Elevation of satellite in degrees.
Azimuth	Int	1	3	Azimuth of satellite in degrees.
SNR	Int	(0) 1	2	Signal to noise ration in dBHz, null if the sv is not in tracking.
Satellite Id	Int	2	2	Satellite vehicle 3.
Elevation	Int	1	3	Elevation of satellite in degrees.
Azimuth	Int	1	3	Azimuth of satellite in degrees.
SNR	Int	(0) 1	2	Signal to noise ration in dBHz, null if the sv is not in tracking.
Satellite Id	Int	2	2	Satellite vehicle 4.
Elevation	Int	1	3	Elevation of satellite in degrees.
Azimuth	Int	1	3	Azimuth of satellite in degrees.
SNR	Int	(0) 1	2	Signal to noise ration in dBHz, null if the sv is not in tracking.
Checksum	*xx	(0) 3	3	2 digits.
Message terminator	<CR> <LF>	2	2	ASCII 13, ASCII 10.

\$GPRMC

This message transfers recommended minimum specific GNSS data. The \$GPRMC message format is shown below.

Field	Format	Min chars	Max chars	Notes
Message ID	\$GPRMC	6	6	RMC protocol header.
UTC Time	hhmmss.sss	1,2,2.1	2,2,2.3	Fix time to 1ms accuracy.
Status	char	1	1	A Data Valid. V Data invalid.
Latitude	Float	1,2.1	3,2.4	Degrees * 100 + minutes.
N/S Indicator	Char	1	1	N=north or S=south.
Longitude	Float	1,2.1	3,2.4	Degrees * 100 + minutes.
E/W indicator	Char	1	1	E=east or W=west.
Speed over ground	Float	1,1	5.3	Speed over ground in knots.
Course over ground	Float	1.1	3.2	Course over ground in degrees.
Date	ddmmyy	2,2,2	2,2,2	Current date.
Magnetic variation	Blank	(0)	(0)	Not used.
E/W indicator	Blank	(0)	(0)	Not used.
Mode	Char	1	1	A Autonomous
Checksum	*xx	(0) 3	3	2 digits.
Message terminator	<CR> <LF>	2	2	ASCII 13, ASCII 10.

\$GPVTG

This message transfers Velocity, course over ground, and ground speed. The \$GPVTG message format is shown below.

Field	Format	Min chars	Max chars	Notes
Message ID	\$GPVTG	6	6	VTG protocol header.
Course (true)	Float	1.1	3.2	Measured heading in degrees.
Reference	Char	1	1	T = true heading.
Course (magnetic)	Float	1.1	3.2	Measured heading (blank).
Reference	Char	1	1	M = magnetic heading.
Speed	Float	1.1	4.2	Speed in knots.
Units	Char	1	1	N = knots.
Speed	Float	1.1	4.2	Speed
units	Char	1	1	K = Km/h.
Mode	Char	1	1	A Autonomous
Checksum	*xx	(0) 3	3	2 digits.
Message terminator	<CR> <LF>	2	2	ASCII 13, ASCII 10.

\$GPZDA

This message transfers UTC Time and Date. Since the latency of preparing and transferring the message is variable, and the time does not refer to a particular position fix, the second precision is reduced to 2 decimal places. The \$GPZGA message format is shown below.

Field	Format	Min chars	Max chars	Notes
Message ID	\$GPZDA	6	6	ZDA protocol header.
UTC time	hhmmss.ss	2,2,2.2	2,2,2.2	00000000.00 to 235959.99
UTC day	dd	2	2	01 to 31, day of month.
UTC month	mm	2	2	01 to 12.
UTC Year	yyyy	4	4	1989-9999.
Local zone hours	Int	(-2)	(-2)	Offset of local time zone (-13) to 13.
Local zone minutes	Unsigned	2	2	
Checksum	*xx	(0) 3	3	2 digits.
Message terminator	<CR> <LF>	2	2	ASCII 13, ASCII 10.

Extensions Specification

For all \$PNMRX messages it is possible to configure an alternative string to replace the NMRX part, the node always responds to the \$PNMRX strings and can be configured to generate and respond to the alternative string.

\$PNMRX100, Set serial port mode

This message is sent to control the serial communications port parameters. The \$PNMRX100 message format is shown below.

Field	Format	Min chars	Max chars	Notes
Message ID	\$PNMRX100	6	6	PNMRX100 protocol header.
Protocol	Char	1	1	0 NMEA mode 1 Nemerix Binary Mode (under dev)
Baud	Int	4	6	1200. 2400. 4800. 9600. 19200. 38400. 57600.
Parity	Char	1	1	0. None. 1. Odd. 2. Even.
Checksum	*xx	(0) 3	3	2 digits.
Message terminator	<CR> <LF>	2	2	ASCII 13, ASCII 10.

Examples:

\$PNMRX100,0,4800,0*xx: sets the UART baud rate to 4800 bps and no parity.

\$PNMRX101, Navigation Initialization

This message is sent to initialize navigation parameters to speed up initial acquisition time. The \$PNMRX101 message format is shown below.

Field	Format	Min chars	Max chars	Notes
Message ID	\$PNMRX101	6	8	PNMRX101 protocol header.
ECEF_X	Int	(-)7	(-)7	Signed ECEF x co-ordinate in meters
ECEF_Y	Int	(-)7	(-)7	Signed ECEF y co-ordinate in meters
ECEF_Z	Int	(-)7	(-)7	Signed ECEF z co-ordinate in meters
Clock offset	Int	(0) 1	6	Clock offset of GPS receiver, in [Hz x 100] wrt L1. This changes the clock bias stored in the settings not the actual clock bias used by the system. A cold start is necessary, in order to use this value.
Time of week	Int	1	6	Offset from start of week in seconds
Week number	Int	1	4	GPS week number
Channel count	Int	1	2	Maximum number of TM to be used. Min 12, max 16.
Checksum	*xx	(0) 3	3	2 digits.
Message terminator	<CR> <LF>	2	2	ASCII 13, ASCII 10.

- If used, all three X,Y, and Z components of the ECEF position must be provided, otherwise the message is declared invalid as a whole
- Modifying the ECEF coordinates triggers a software system reset after successful execution of the message

Examples:

\$PNMRX101,,,,,,,,,8,*xx:

Executes a factory reset

\$PNMRX101,-742507,-5462738, 3196706,*xx: Sets the receiver position to ECEF (,) and executes a software reset

\$PNMRX101, 4,*xx:

Sets the fix procedure mode the cold start. This will be valid after each reset, until this value is changed.

\$PNMRX103, NMEA rate control

This message is being sent to enable or to disable the output of an NMEA message and to determine its output rate. The sequence of the output sequence is determined by the \$PNMRX107 message. The \$PNMRX103 message format is shown below. The rate of each message can individually be set. If '0' is used, the output of the message is skipped (according to the message sequence). The message length is limited to 80 characters, in the event that the message length would exceed 80 characters it is divided into 2 messages. This message is supported also in a variable length format, where only the necessary fields are used.

Field	Format	Min chars	Max chars	Notes
Message ID	\$PNMRX103	8	8	PNMRX103 protocol header.
Mask ID	Int	3	3	Mask identifier: possibilities are GGA GLL GSA GSV RMC VTG ZDA ALL (applies to all messages)
Mask value	Int	1	1	Output rate in seconds (0=paused)
Mask ID	Int	2	2	Mask identifier.
Checksum	*xx	(0) 3	3	2 digits.
Message terminator	<CR> <LF>	2	2	ASCII 13, ASCII 10.

Examples:

\$PNMRX103, GSV, 2,GGA, 1,ZDA, 0*xx: GSV is output every 2s,GGA every 1s and ZDA is skipped.

\$PNMRX103, GSV, 2, GGA, 1, ZDA, 0,*xx: same as above, but using a fixed length message

\$PNMRX103, ALL, 2*xx: all messages are output every 2s.

\$PNMRX103, ALL, 0*xx: skips all messages.

\$PNMRX104, LLA navigation initialization

This message enables the receiver to be initialized using LLA data to speed up satellite acquisition. The first 4 values defining the position (if used) must be all present in the message. Otherwise the whole message is considered invalid.

Field	Format	Min chars	Max chars	Notes
Message ID	\$PNMRX104	8	8	PNMRX104 protocol header. (Under dev.)
Latitude	Float	1,2.1	3,2.4	Degrees * 100 + minutes. (Under dev.)
N/S Indicator	Char	1	1	N=north or S=south. (Under dev.)
Latitude	Float	1,2.1	3,2.4	Degrees * 100 + minutes. (Under dev.)
E/W Indicator	Char	1	1	E=east or W=west. (Under dev.)
Altitude	Int	(-) 1	(-) 6	Altitude above MSL, in meters.
Clock offset	Int	(0) 1	6	Clock offset of GPS receiver. These changes the clock bias stored in the settings, not the actual clock bias used by the system. A cold start is necessary, in order to use this value.
Time of week	Int	1	6	Offset from start of week in seconds. (Under dev.)
Week number	Int	1	4	GPS week number.
Channel count	Int	1	2	Maximum number of TM to be used. Min12, max 16.
Checksum	*xx	(0) 3	3	2 digits.
Message terminator	<CR> <LF>	2	2	ASCII 13, ASCII 10.

- **If used, all five components (Lat, N/S, Long E/W, alt) of the LLA position must be provided, otherwise the message is declared invalid as a whole**
- **Modifying the LLA coordinates triggers a software system reset after successful execution of the message.**

\$PNMRX106, Datum

This message defines the conversion model used for mapping the ECEF coordinates into the LLA ones. The default transformation uses WGS84 approximation. The transformation method can be changed into one using a reference Ellipsoid combined with a local datum, to obtain a specific estimation of the local earth geometry. Once the datum has been changed it will be applied to all LLA data, including the LLA navigation initialization Data. This message enables the receiver to be configured to use map datum from an internal table, or datum supplied as part of the message.

Field	Format	Min chars	Max chars	Notes
Message ID	\$PNMRX106	6	8	PNMRX106 protocol header.
Correction Mode	Unsigned	1	1	If 1 apply EGM96 geoids correction (warning: should be applied only when Map Datum is equal to 216). If 0 there is no EGM96 geoids correction.
Map Datum	Int	(0) 1	3	Reference number of the appropriate map datum to apply.
				0-218 Map datum from internal table 500 User defined Datum
Dx	Int	(0) (-)1	(-)5	X offset in meters (-9999 to 9999)
Dy	Int	(0) (-)1	(-)5	Y offset in meters (-9999 to 9999)
Dz	Int	(0) (-)1	(-)5	Z offset in meters (-9999 to 9999)
Iflat	Int	(0) 1	8	Inverse flatness of reference geode. The value to be used is (IFlat – 290) * 1000000). The value must be in the range [6000000, 12000000]
Majora	Int	(0) 1	8	Semi major axis of reference geode. The values to be used is (MajorA – 6370000) * 1000). The value must be in the range [6000000, 9000000]
Checksum	*xx	(0) 3	3	2 digits.
Message terminator	<CR> <LF>	2	2	ASCII 13, ASCII 10.

Examples:

\$PNMRX106, 0,500, -2000,-2000,-2000, 8257224, 8137000*00*xx: **User defined Datum**

\$PNMRX106, 1, 216,*xx:

WGS 84 Datum

\$PNMRX107, Messages rate control

This message is sent to set the automatic update rate, and to configure which messages will be automatically output, it is also sent from the node to report which messages are currently configured for automatic transmission. The \$PNMRX107 message format is shown below. This message can be used to enable and disable multiple messages by including up to 4 message codes and associated fields in each \$PNMRX107 message.

The message length is limited to 80 characters, in the event that the message length would exceed 80 characters it is divided into 2 messages. This message is supported also in a variable length format, where only the necessary fields are used.

Field	Format	Min chars	Max chars	Notes
Message ID	\$PNMRX107	8	8	PNMRX107 protocol header.
Message code	Char	3	3	Determines which message is being configured. 300 PNMRX300 Almanac Data 301 PNMRX301 Ephemeris Data 302 PNMRX302 lonospheric corrections 303 PNMRX303 UTC Time 304 PNMRX304 GPS constellation health ALL Applies to all messages
Mode	Int	1	1	0 Disable message 1 Send message now 2 Send message on change 3 Send message now and on change
Checksum	*xx	(0) 3	3	2 digits.
Message terminator	<CR> <LF>	2	2	ASCII 13, ASCII 10.

Examples:

\$PNMRX107, 300, 1*xx: **Output the almanac stored in NVRAM**

\$PNMRX107, 301, 2*xx: **Output Ephemeris will be output on change**

\$PNMRX107, ALL, 2*xx: **Output all GE415 output messages (300,301,302,303,304)**

\$PNMRX108, NMEA message sequence

This message is used to set the sequence used to output the NMEA messages. All messages in the list are set to be output with a default output rate. The messages that are not included are disabled. Once the sequence is defined, individual settings for the messages can be changed by means of the \$PNMRX103 message. This message is supported also in a variable length format, where only the necessary fields are used.

Field	Format	Min chars	Max chars	Notes
Message ID	\$PNMRX108	6	8	PNMRX108 protocol header.
Mask ID	Int	3	3	Mask identifier: possibilities are GGA GLL GSA GSV RMC VTG ZDA
Mask ID	Int	3	3	Mask Identifier.
Checksum	*xx	(0) 3	3	2 digits.
Message terminator	<CR> <LF>	2	2	ASCII 13, ASCII 10.

Examples:

\$PNMRX108, GGA, GLL, and GSA*xx: Enables the GGA, GLL and GSA in this sequence, output

Every second. All other messages are disabled

\$PNMRX110, Fix Settings

This message is used to set various settings and masks which control how the software will behave in relationship to the satellites in view, for example a mask can be set for the minimum satellite elevation, minimum SNR etc. The message consists of a varying number of fields depending on the number of masks to be set. Each mask setting consists if a mask identifier and new value pair. The \$PNMRX110 message format is shown below.

PNMRX110 field list

Field	Format	Min chars	Max chars	Notes
Message ID	\$PNMRX110	6	8	PNMRX110 protocol header.
Mask ID	Int	2	2	Mask identifier, see below.
Value	Variant	1	8	New value for mask, dependent on the preceding field, see below.
Mask ID	Int	2	2	Mask identifier.
Value	Variant	1	8	New value for mask, dependent on the preceding field.
Checksum	*xx	(0) 3	3	2 digits.
Message terminator	<CR> <LF>	2	2	ASCII 13, ASCII 10.

PNMRX110 Mask Field interpretation

Mask Id	mask	format	width	units
0	Local Time Zone	Int: unsigned	2:2	Hours : Minutes
1	Maximum PDOP ¹	Unsigned	4	x10, [0-100]
2	Maximum HDOP	Unsigned	4	x10, [0-100]
3	Maximum VDOP ¹	Unsigned	4	x10, [0-100]
4	Minimum SNR	Unsigned	2	dB/Hz, [20-45]
5	Minimum Elevation	Unsigned	2	Degrees, [0-90]
6	Noise Floor	Unsigned	4	-, [400-1000]
7	Navigation Mode 1 ¹	Unsigned	1	1 = Auto (hold alt) 2 = 2D Mode 4 = 3D Mode (calc alt)
8	2D Mode Altitude ¹	Unsigned	6	Meters above MSL
9	Navigation Mode 2 ¹	Boolean	1	0 = Auto 1 = Static
10	Maximum Altitude	Unsigned	6	Meters.

Examples:

\$PNMRX110, 0,-2:0*xx: **Set the local time to –2 hours 0 minutes.**

\$PNMRX110, 4, 35*xx: **Set the minimum SNR to 35**

\$PNMRX111, Software reset

This message is used to reset the systems. If the message is sent without parameters the receiver reboots according to the fix procedure (hot, warm or cold) configured with the PNMRX101 or PNMRX104 messages. A second parameter can optionally be used to specify which actions are executed after the reset. If the last bit field is set to '1', then the actions are repeated permanently at each reset, until this bit is cleared.

Field	Format	Min chars	Max chars	Notes																										
Message ID	\$PNMRX111	6	8	PNMRX111 protocol header.																										
Invalidate parameter	Integer OR String	1	7	<p>If integer, the bit field have the following meaning (the action described is executed if the bit is 1):</p> <table border="0"> <thead> <tr> <th>Field</th> <th>Action</th> </tr> </thead> <tbody> <tr> <td>0</td> <td>Reload settings from Flash</td> </tr> <tr> <td>1</td> <td>Clear almanac data and don't load if from flash</td> </tr> <tr> <td>2</td> <td>Clear Ephemeris data</td> </tr> <tr> <td>3</td> <td>Clear ionosphere and troposphere corrections</td> </tr> <tr> <td>4</td> <td>Invalidate stored position</td> </tr> <tr> <td>5</td> <td>Invalidate stored time</td> </tr> <tr> <td>6</td> <td>Copy oscillator offset from Settings</td> </tr> <tr> <td>7</td> <td>Sticky bit –if '1' the action are repeated at each reset</td> </tr> </tbody> </table> <p>If String, the following values are allowed:</p> <table border="0"> <tbody> <tr> <td>FACTORY</td> <td>See Section 2.1 for definition.</td> </tr> <tr> <td>COLD</td> <td>See Section 2.1 for definition.</td> </tr> <tr> <td>WARM</td> <td>See Section 2.1 for definition.</td> </tr> <tr> <td>HOT</td> <td>See Section 2.1 for definition.</td> </tr> </tbody> </table>	Field	Action	0	Reload settings from Flash	1	Clear almanac data and don't load if from flash	2	Clear Ephemeris data	3	Clear ionosphere and troposphere corrections	4	Invalidate stored position	5	Invalidate stored time	6	Copy oscillator offset from Settings	7	Sticky bit –if '1' the action are repeated at each reset	FACTORY	See Section 2.1 for definition.	COLD	See Section 2.1 for definition.	WARM	See Section 2.1 for definition.	HOT	See Section 2.1 for definition.
Field	Action																													
0	Reload settings from Flash																													
1	Clear almanac data and don't load if from flash																													
2	Clear Ephemeris data																													
3	Clear ionosphere and troposphere corrections																													
4	Invalidate stored position																													
5	Invalidate stored time																													
6	Copy oscillator offset from Settings																													
7	Sticky bit –if '1' the action are repeated at each reset																													
FACTORY	See Section 2.1 for definition.																													
COLD	See Section 2.1 for definition.																													
WARM	See Section 2.1 for definition.																													
HOT	See Section 2.1 for definition.																													
Checksum	*xx	(0) 3	3	2 digits.																										
Message terminator	<CR> <LF>	2	2	ASCII 13, ASCII 10.																										

Examples:

\$PNMRX111*xx: **Resets the system**

\$PNMRX112, Power Mode Control

This message is used to configure the operating modes of the receiver. Low power modes can be activated and configured. Low power mode starts to work only after the receiver has a complete and up to date almanac and it can produce the fix.

Field	Format	Min chars	Max chars	Notes
Message ID	\$PNMRX112	6	8	PNMRX112 protocol header.
Operating Mode	Into	1	1	0 = Fully Active 1 = LDCM1
OFF period	Into	1	2	RF off time in seconds [5:10]
Checksum	*xx	(0) 3	3	2 digits.
Message terminator	<CR> <LF>	2	2	ASCII 13, ASCII 10.

Examples:

\$PNMRX112, 1, 5*xx: **enable low power mode (with 5 seconds off time between 2 fixes)**

\$PNMRX113, GPS Core Activity Control

This message is used to disable GPS Core activities (data extraction and fix generation) on the node. The goal of this message is to disable these two functions when they need to be overwritten by external values for test purpose. A reset message must be set after the PNMRX113 in order to resume operation. For instance if a different almanac needs to be downloaded to the receiver then, data extraction must be disabled, then the new almanac can be downloaded. A reset command will then be used to restore operation with hen new almanac.

Field	Format	Min chars	Max chars	Notes
Message ID	\$PNMRX113	6	8	PNMRX113 protocol header.
Checksum	*xx	(0) 3	3	2 digits.
Message terminator	<CR> <LF>	2	2	ASCII 13, ASCII 10.

Examples:

\$PNMRX113*xx: **Stops GPS Core activities.**

\$PNMRX300, Almanac Data Transfer

This message format is used to transfer the almanac data between nodes; it uses a packed hexadecimal format to transfer almanac data for each of the available SV's. Since the Almanac data is large and can take time to transfer over a slow serial interface, the data is divided into individual messages for each of the SV's. These messages are transmitted sequentially and can be interleaved with other messages to prevent the Almanac data blocking higher priority messages such as scheduled PVT information. The data for these messages is expressed as signed or unsigned fixed point values which have been scaled from the floating point values used in the position solution. The appropriate scaling factors are included in the table. There is 1 message for each satellite for which data is available. When transmitted these messages are generated in ascending order of SV Id, when being sent to the node these can be sent in any order, each message is individually interpreted and processed.

Field	Format	width	scale	Notes
Message ID	\$PNMRX300	8		PNMRX300 protocol header.
SV Id	Int	2		Decimal Satellite vehicle Id from 1 to 32.
e	Hex	4	2^{-21}	16 bit signed int, scale.
Health	Hex	2		Bitmap of satellite health.
T _{oa}	Hex	2		Week Number
i	Hex	4	2^{-19}	16 bit signed int.
Omega dot	Hex	4	2^{-38}	16 bit signed int.
Root_A	Hex	6	2^{-11}	24 bit unsigned int.
Omegazero	Hex	6	2^{-23}	24 bit signed int.
Perigee	Hex	6	2^{-23}	24 bit signed int.
Mean	Hex	6	2^{-23}	24 bit signed int.
Mean anomaly	Hex	6	2^{-23}	24 bit signed int.
af0	Hex	6	2^{-20}	11 bit signed int.
af1	Hex	6	2^{-68}	11 bit signed int.
Checksum	*xx	(0) 3		2 digits.
Message terminator	<CR> <LF>	2		ASCII 13, ASCII 10.

\$PNMRX301, Ephemeris Data Transfer

This message format is used to transfer the ephemeris data between nodes; it uses a packed hexadecimal format to transfer ephemeris data for each of the available SV's. Since the Ephemeris data is large and can take time to transfer over a slow serial interface, the data is divided into individual messages for each of the SV's. These messages are transmitted sequentially and can be interleaved with other messages to prevent the Ephemeris data blocking higher priority messages such as scheduled PVT information. The data for these messages is expressed as signed or unsigned fixed point values which have been scaled from the floating point values used in the position solution. The appropriate scaling factors are included in the table. The ephemeris data for each satellite is divided into 3 separate messages with sequence numbers to identify them, the contents of these frames reflects the contents of the appropriate subframes 1,2,3 transmitted from the SV's. When transmitted these messages are generated in ascending order of SV Id and sequence number, when being sent to the node these can be sent in any order, provided that the 3 messages for any individual satellite are grouped together, each message is individually interpreted and after a group of 3 valid messages for an SV the ephemeris for that SV is updated independently. The 3 message formats are illustrated in the following tables

PNMRX301 message 1 field list

Field	Format	width	scale	Units	Notes
Message ID	\$PNMRX301	8			PNMRX301 protocol header.
Satellite vehicle Id	Int	2			Decimal satellite vehicle Id from 1 to 32.
Subframe Id	Int	1			Subframe number 1.
Week number	Hex	3		Weeks	10 bit week number.
Health	Hex	2			6 bits.
URA	Hex	1			User range accuracy.
Time Group Delay	Hex	2	2^{-31}	Seconds	8 bits.
IODC	Hex	3			10 bit integer.
Toc	Hex	4	2^{-4}		16 bits.
Af2	Hex	2	2^{-31}	sec/sec ²	8 bit signed integer.
Af1	Hex	4	2^{-43}	sec/sec	16 bit signed integer.
Af0	Hex	6	2^{-31}	Seconds	22 bit signed integer.
Checksum	*xx	(0) 3			2 digits.
Message terminator	<CR> <LF>	2			ASCII 13, ASCII 10.

PNMRX301 message 2 field list

Field	Format	width	scale	units	Notes
Message ID	\$PNMRX301	8			PNMRX301 protocol header.
Satellite Vehicle Id	Int	2			Decimal satellite vehicle id from 1 to 32.
Subframe Id	Int	1			Subframe number 2.
Iode	Hex	2			8 bits, lower 8 bits of matching iodc.
Crs	Hex	4	2^{-5}	Meters	16 bit signed integer.
Motion difference (n)	Hex	4	2^{-43}	Semi-circles/sec	16 bit signed integer.
Mean anomaly	Hex	8	2^{-31}	Semi-circles	32 bit signed integer.
Cuc	Hex	4	2^{-29}	Radians	16 bit signed integer.
E	Hex	8	2^{-33}		32 bit signed integer.
Cuc	Hex	4	2^{-29}	Radians	16 bit signed integer.
Root A	Hex	8	2^{-19}	Meters ^{1/4}	32 bit signed integer.
Toe	Hex	4	2^4	seconds	16 bit unsigned integer.
Checksum	*xx	(0) 3			2 digits.
Message terminator	<CR> <LF>	2			ASCII 13, ASCII 10.

PNMRX301 message 3 field list

Field	Format	width	scale	units	Notes
Message ID	\$PNMRX301	8			PNMRX301 protocol header.
Satellite Vehicle Id	Int	2			Decimal satellite vehicle id from 1 to 32.
Subframe Id	Int	1			Subframe number 3.
Cic	Hex	4	2^{-29}	Radians	16 bit signed integer.
Omega zero	Hex	8	2^{-31}	Semi-circles	32 bit signed integer.
Cis	Hex	4	2^{-29}	radians	16 bit signed integer.
I Zero	Hex	4	2^{-31}	Semi-circles	32 bit signed integer.
Crc	Hex	4	2^{-5}	Meters	16 bit signed integer.
Perigree	Hex	8	2^{-31}	Semi-circles	32 bit signed integer.
Omega dot	Hex	6	2^{-43}	Semi-circles/sec	24 bit signed integer.
Iode	Hex	2			Lower 8 bits of matching iodc.
I dot	Hex	4	2^{-43}	Semi-circles/sec	14 bit signed integer.
Checksum	*xx	(0) 3			2 digits.
Message terminator	<CR> <LF>	2			ASCII 13, ASCII 10.

\$PNMRX302, Ionospheric correction

Field	Format	width	scale	units	Notes
Message ID	\$PNMRX302	8			PNMRX301 protocol header.
Satellite Vehicle Id	Int	2			Decimal satellite vehicle id from 1 to 32.
$\alpha 0$	Hex	2	2^{-30}		
$\alpha 1$	Hex	2	2^{-27}		
$\alpha 2$	Hex	2	2^{-24}		
$\alpha 3$	Hex	2	2^{-24}		
$\beta 0$	Hex	2	2^{11}		
$\beta 1$	Hex	2	2^{14}		
$\beta 2$	Hex	2	2^{16}		
$\beta 3$	Hex	2	2^{16}		
Checksum	*xx	(0) 3			2 digits.
Message terminator	<CR> <LF>	2			ASCII 13, ASCII 10.

\$PNMRX303, UTC time

Field	Format	width	scale	units	Notes
Message ID	\$PNMRX303	8			PNMRX301 protocol header.
Satellite Vehicle Id	Int	8			Decimal satellite vehicle id from 1 to 32.
Data – A0	Hex	2			Constant term of the polynomial
Data – A1	Hex	2			First-order term of the polynomial.
Delta t LS	Hex	2			Delta time due to leap seconds.
Tot	Hex	2			Reference time for UTC.
WNt	Hex	2			UTC reference week number
WNlsf	Hex	2			Week number at which the leap second becomes effective.
DN	Hex	2			Day number B2.
Delta t LSF	Hex	2			Delta time due to leap seconds if leap second is in the past.
NumBlocks	Hex	2			Number of 20 year blocks
Time Offset	Hex	2			Time offset for current time zone
Checksum	*xx	(0) 3			2 digits.
Message terminator	<CR> <LF>	2			ASCII 13, ASCII 10.

\$PNMRX304, GPS Constellation Health

Field	Format	Min chars	Max chars	Notes
Message ID	\$PNMRX304	8	8	PNMRX110 protocol header.
Health Code	Char	TBD	TBD	SV health code if 0.
Health Code	Char	TBD	TBD	SV health code if 0.
Checksum	*xx	(0) 3	3	2 digits.
Message terminator	<CR> <LF>	2	2	ASCII 13, ASCII 10.

\$PNMRX600, Report Software Version

By sending the \$PNMRX600*00 string to the receiver, the version of the software is output.

\$PNMRX601, Enter ISP mode

By sending the \$PNMRX601*00 string to the receiver, the receiver enters ISP mode.

\$PNMRX603, Settings report

By sending the \$PNMRX603*00 string to the receiver, the current value of the settings is output. The content of settings is split in 4 messages.

PNMRX603 message 0

Field	Format	Min chars	Max chars	Notes
Message ID	\$PNMRX603	8	8	PNMRX603 protocol header.
Message Nb	Int	1	1	0
Message Sequence (7 times)	7xInt	1	1	Message Sequence
Message Delay (7 times)	7xInt	1	1	Message Delay
NMRX Message Enabled	Hex	8	8	Nemerix Message Enabled
Uart Settings	Hex	8	8	Uart settings
Checksum	*xx	(0) 3	3	2 digits.
Message terminator	<CR> <LF>	2	2	ASCII 13, ASCII 10.

PNMRX603 message 1

Field	Format	Min chars	Max chars	Notes
Message ID	\$PNMRX603	8	8	PNMRX603 protocol header.
Message Nb	Int	1	1	1
Ionospheric Data A0	Hex	2	2	Ionospheric correction 0 coefficient.
Ionospheric Data A1	Hex	2	2	Ionospheric correction 1 coefficient.
Ionospheric Data A2	Hex	2	2	Ionospheric correction 2 coefficient.
Ionospheric Data A3	Hex	2	2	Ionospheric correction 3 coefficient.
Ionospheric Data B0	Hex	2	2	Ionospheric correction 0 coefficient.
Ionospheric Data B1	Hex	2	2	Ionospheric correction 1 coefficient.
Ionospheric Data B2	Hex	2	2	Ionospheric correction 2 coefficient.
Ionospheric Data B3	Hex	2	2	Ionospheric correction 3 coefficient.
Ionospheric Data Valid	Hex	1	1	Ionospheric Data Valid. If 0 the data are invalid.
Num Blocks	Hex	1	1	Number of 20 year blocks
Time Offset (Local zone hours)	Int	(-2)	(-2)	Offset of local time zone (-13) to 13
Time Offset (Local zone minutes)	Int	(-2)	(-2)	
Checksum	*xx	(0) 3	3	2 digits.
Message terminator	<CR> <LF>	2	2	ASCII 13, ASCII 10.

NMRX603 message 2

Field	Format	Min chars	Max chars	Notes
Message ID	\$PNMRX603	8	8	PNMRX603 protocol header.
Message Nb	Int	1	1	2
MaxPDOP	Float			
MaxHDOP	Float			
Invalid Sv	Hex	8	8	
Min CNO	Float			
Min Elevation	Float			
Max TM	Int	2	2	
Max Sv for fix	Int	2	2	
Checksum	*xx	(0) 3	3	2 digits.
Message terminator	<CR> <LF>	2	2	ASCII 13, ASCII 10.

PNMRX603 message 3

Field	Format	Min chars	Max chars	Notes
Message ID	\$PNMRX603	8	8	PNMRX603 protocol header.
Message Nb	Int	1	1	3
Acq threshold 1	Int	3	8	
Acq threshold 2	Int	3	8	
Noise floor	Int	3	8	
Kalman Mode	Hex	1	1	
Default altitude	Int	1	8	
Checksum	*xx	(0) 3	3	2 digits.
Message terminator	<CR> <LF>	2	2	ASCII 13, ASCII 10.

PNMRX603 message 4

Field	Format	Min chars	Max chars	Notes
Message ID	\$PNMRX603	8	8	PNMRX603 protocol header.
Message Nb	Int	1	1	4
Correction Mode	Int	1	1	EGM96 geoids correction
Map Datum	Int	1	8	Reference number of the appropriate map datum to apply
Dx	Int	1	8	x offset in meters
Dy	Int	1	8	y offset in meters
Dz	Int	1	8	z offset in meters
Inverse flatness	Int	1	8	Inverse flatness of reference geode
Major axis	Int	1	8	Semi major axis of reference geode
Checksum	*xx	(0) 3	3	2 digits.
Message terminator	<CR> <LF>	2	2	ASCII 13, ASCII 10.

Examples:

\$PNMRX603*xx: **Display the content of the Settings stored in NVRam**